

FULLY WELDED BALL VALVE (FAF 1270)



APPLICATIONS:

Steam, cold water, hot water and pressurized hot water installations, chemical fluids, compressed air, etc.

TEMPERATURE:

Max. +200°C
Working Pressure: 25 bar

PRODUCT FEATURES:

- One piece body
- Blow-out proof stem
- High precision ball made of Stainless Steel Grade 304
- Body and piping material can be chosen from the wide range of steel piping materials according to customers' requirements. Standard production with St37 Steel
- Quarter-turn operation
- Reduced bore
- Bi-directional

FULLY WELDED BALL VALVE (FAF 1270)

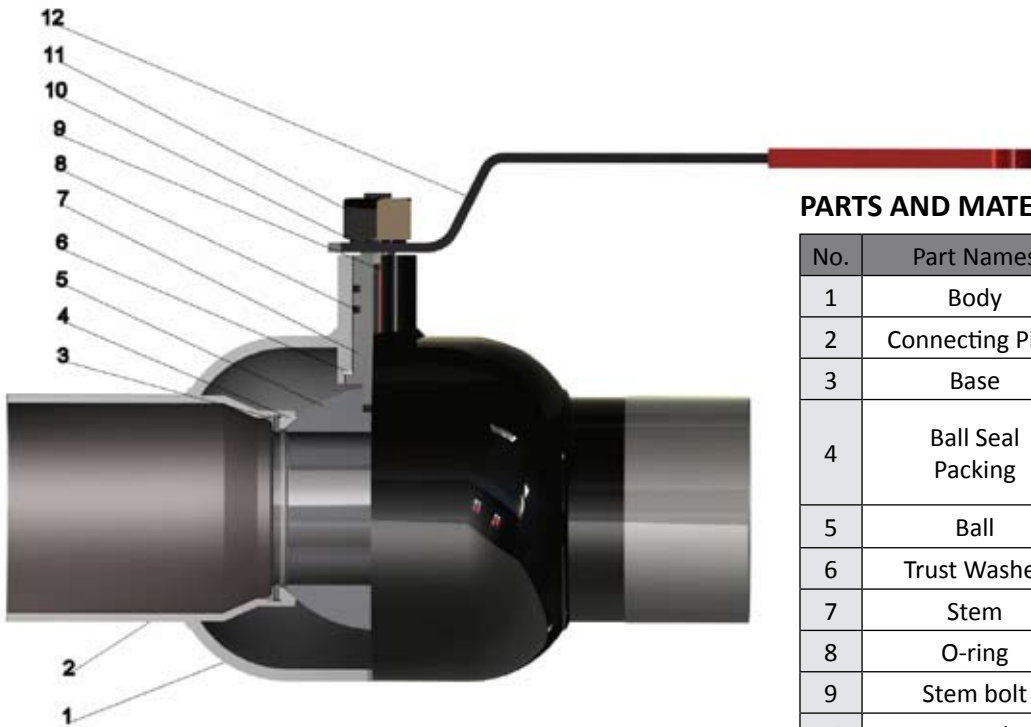

PARTS AND MATERIALS

| No. | Part Names | Material |
|-----|-------------------|--------------------------|
| 1 | Body | St 37 |
| 2 | Connecting Pipe | St 37 |
| 3 | Base | St 37 |
| 4 | Ball Seal Packing | AISI 420, Silicone, PTFE |
| 5 | Ball | DIN1.4086 |
| 6 | Trust Washer | PTFE |
| 7 | Stem | 303 SS |
| 8 | O-ring | Viton |
| 9 | Stem bolt | AISI 420 |
| 10 | Nut Washer | DIN 439 |
| 11 | Hexagon Nut | DIN 934 |
| 12 | Handle | St37 |

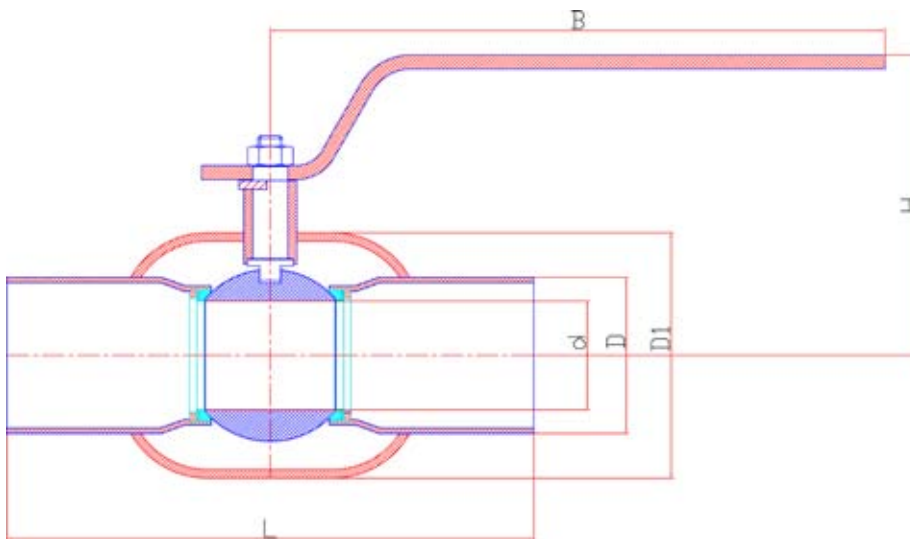

DIMENSION TABLE

| DN (mm) | D | D1 | d | L | H | B | W(kg) |
|---------|-------|-------|-----|-----|-----|-----|-------|
| 40 | 48.3 | 76.1 | 30 | 260 | 100 | 165 | 2.3 |
| 50 | 60.3 | 88.9 | 38 | 300 | 115 | 200 | 3.6 |
| 65 | 76.1 | 114.3 | 47 | 300 | 123 | 225 | 5 |
| 80 | 88.9 | 139.7 | 62 | 300 | 135 | 250 | 7 |
| 100 | 114.3 | 165.1 | 76 | 325 | 143 | 300 | 10.8 |
| 125 | 139.7 | 178 | 96 | 325 | 213 | 350 | 19.4 |
| 150 | 165.1 | 219.1 | 119 | 350 | 230 | 550 | 29.4 |